

# T2 HEATED EAVE PANEL (12")

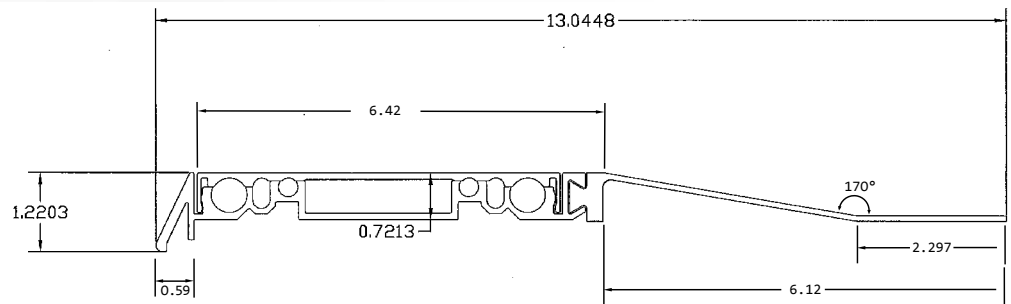

T-Panels can be installed on new or existing roofs.

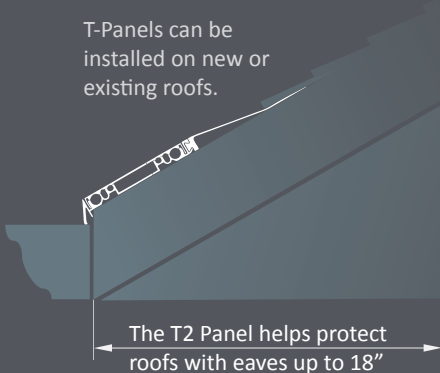

The T2 Panel helps protect roofs with eaves up to 18"

## T2 EAVE PANEL

The T2 system is 12" wide and has an exposed, heated surface area of 10". Thermal Technologies' innovative roof snow and ice elimination systems are attractive and cost effective. They ensure that the building's owner will not have the frustration, property damage, and costs associated with water damage caused by the inability of roofs to drain water during winter months.

### SPECIFICATIONS

Material Selection	♻️ Recycled Aluminum Alloy 6063 Temper - T5
Color	Spray Powder Coating Colors
Panel Size	12" x 6'—Designed to help eliminate icicles and ice dams on roof eaves up to 18" wide.
Heating Systems	Commercial Grade-Self Regulating Heat Cable (5, 8 or 10 Watt per foot in 100-130 VAC or 208-277 VAC) or 3/8" PEX Hydronic Radiant Tubing
Product Finish	High Grade Powder Coating or Architectural Decorative Cover
Components	6" Aluminium Alloy Snap-Loc Top, 6" Aluminum Alloy Eave Base Panel, 6" Aluminum Alloy Transition and Aluminum Expansion Joint Cap (EJC). Choose either 2' electric heat cable or 2' of hydronic PEX tubing per foot.
Optional Items	System controller, Self regulating heat trace for gutters and downspouts
Electrical Requirements	N.E.C. 426-28 requires 30 mA Ground Fault circuit protection for snow and ice melting applications

#### Prevent Ice Dams with T-Panels

Heat from the sun and warmth from the attic partially melt roof snow, creating a trickle of water which freezes at the roof's edge. If left untreated, ice dams and icicles can form.

The T-Panel System melts and prevents property-damaging ice dams, the formation of dangerous icicles and heavy snow load. There's no longer a need to shovel and scrape away snow and ice.



**THERMAL**  
TECHNOLOGIES

(866) 635-8123

www.thermaltechusa.com

INNOVATIVE  
ROOF DE-ICING  
SYSTEMS

